

THE MICROBIBLIOPHILE®

A Bimonthly Journal about Miniature Books and the Book Arts

Volume XXXIX, Number 3 Issue 225, May - June 2020

AN ABBREVIATED GLIMPSE OF THE WORLD OF THE JOURNAL:
SUBSCRIBE TODAY !



Hazy, Hot, and Humid...it's Summer

Single Issue Price: \$7.00

ISSN #1097-5551

Thoughts for a New Miniature Book

By the 'keeper of the light'



Images from the USPS 1990 stamp set, 'East Coast Lighthouses'

L to R, 'Admiralty Point', 'Cape Hatteras', 'West Quoddy', 'American Shoals', and 'Sandy Hook'

"Indeed they were very close to the lighthouse now. There it loomed up, stark, and straight, glaring white and black, and one could see the waves breaking in white splinters like smashing glass against the rocks." Virginia Woolf, *To the Lighthouse*, (1927)

Lighthouses always impart a bit of mystery and fascination in the eyes of all that visit these beacons of light that reach out across the sea with their bright beams. How many ships have passed the beam in the darkness of a stormy night, how many steps did the keeper have to climb to light the light, where did the children go to school, where did their drinking water come from? There are so many questions, so many memories, and so many stories, enough to fill many pages of so many books for sure.

To the Lighthouse is a story about a family at their summer home in the Hebrides, on the Isle of Skye, Scotland. Yes, there are a few lighthouse there for sure. Take some time and read Woolf's work, there is certainly more to it than the lighthouse. This issue of *The Microbibliophile* was put together while I visited a lighthouse on Rose Island, in Newport, Rhode Island.

(continued on page 15)

THE MICROBIBLIOPHILE®

A Bimonthly Journal about Miniature Books and the Book Arts

Robert F. Hanson, Founder, 1977

ISSN# 1097-5551

Volume XXXIX, Number 3, Issue Number 225

May, 2020

Book Reviews and Criticism:

The Adventures of Stu , by Kay Embee and Mariam Ahmed	05
Apple Pins , by Nina Masso and Ken Silverman, published by Cider Press	07
The Building of a Railway , by Thomas Curtis Clarke, published by Plum Park Press	08
Canadian Holiday , by W. D. Wilcox, edited & published by The Wild Onion Press	10
Makers of Modern Agriculture , by W. MacDonald, edited & published by The Wild Onion Press	11
Steam on the Niagara River , by B. Cumberland, edited & published by The Wild Onion Press	12
Tilbury and Agincourt , published by Bo Press Miniature Books	13

Special Features:

Frontispiece, <i>continued</i>	15
Not In Adomeit, by Todd Sommerfeld	16
Miniature Music Books, Part I, by Gail Curry	18
Miniature Music MBS Keepsakes, by Stephen Byrne	27
History of the Cadiz Railroad –three versions	29
The Large World of Miniature Books, by Robert F. Orr Hanson	30
Purrings, by Todd Sommerfeld	35
The Miniature Book Collector, by Nina Mazzo	38
Treasure from the Online Book Fair, by Nina Mazzo	40
Duchess of Malfi	42
Ephemeral, Dawson's Book Shop	43
My First Miniature Book Purchase, by Cathie Abney	45

Departments:

Get the Ink Ready, Start the Presses	41
Catalogues Received	47
Terms and Definitions, 'Quads and Type'	48
<i>The Microbibliophile</i> Frontispiece for the July/August 2020 issue	49
Classified	50

The Microbibliophile

P. O. Box 5453, North Branch, NJ 08876 U.S.A.
Sherry Mayo, Publisher James M. Brogan, Editor
© 2020 by James M. Brogan

Greetings from the Squeaky Roll Top Desk:

What a year it has been, things change each day, some for the good and some not exactly so. Too hot, too much rain, not enough rain, life somehow goes on. I am sure that I am not the only one making plans for working with the children to do their 'distance learning' school lessons come September. I certainly have to be thankful for the resources that we have here but I only wish we could help more children as there are scores that have to try to figure things out for themselves because their parents work or they may not have the technology structure to make it all happen each day. I have to take a deep breath each day and say a prayer for everyone to 'carry on as best you can'.

Seven new miniature books are reviewed in this issue. One of the books 'Stu' is by a new author and book artist. Gail Curry continues to charm us with her article on music and miniature books. Stephen Byrne reflects on some of his music related MBS keepsakes. Nina continues the exploration with her series on the MBC. Cathie Abney relates the story of her first miniature book purchase and Todd Sommerfeld talks about Black Cat Press's 'Purrings'. There is also a special article on an 'edition of one' only book.

In the meantime, please share a copy of *The Microbibliophile* with a non-subscribing friend or even the staff at your local library or favorite bookstore. Then, just drop me an email message with the contact information and I will mail out a sample copy to keep on their desk for sharing.

Finally, as always, I ask that you please consider joining other contributors to our little journal by sharing your own creations, possibly your book search adventures and finds, or simply your passion for all things "bookish". If you have an idea, but need composing help, Sherry and I are available to lend a thought or two to get your idea onto paper. Let me know of any ideas for articles of interest to you that might be explored in a future issue; I always enjoy the research .

The production and mailing costs to keep *The Microbibliophile* humming along continue to increase. I hesitate to just say 'the new subscription price is' without asking the readership for your input and suggestions. I can put together a 'survey' but would like to hear from you first. We could shrink the physical size of the publication (not much savings) or we could go to an 'all digital format' with electronic distribution (a big savings and price reduction) but a significant 'format change). Maybe a tiered subscription offering both paper and or electronic publications?

If you have not mailed in your 2020 subscription payment, please do so, we like the USPS cannot run without your support. I hope to have the next issue in the mail by the first week of October.

Your support and interest is what helps keep *The Microbibliophile* an active publication of all things "bookish. 📖

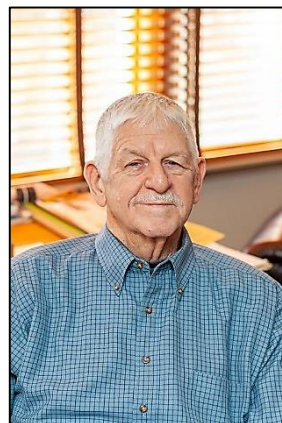

MINIATURE BOOK REVIEWS and CRITICISM:

THE ADVENTURES OF STU, a children's book by Kay Embee and Mariam Ahmed. *The Adventures of Stu* is one of those little treasures that from time to time greet me at the mailbox. Stu makes you say, "Over the hill he went along...whistling a tune and singing a song".

The Adventures of Stu is a three-generation co-operation between a daughter, granddaughter, and the father/grandfather. Quite well done by all!

The following information about 'Stu' was supplied by Stephen Byrne. "As an end of her first year project on a graphic design course at University in Cairo, Egypt, my granddaughter Mariam chose to create the illustrations for a children's book. My daughter Kirstie wrote the text, about a little Scottie dog called Stu, and his various animal friends as they went on a journey to the loch.

The text complete, Mariam set about creating the images to accompany the story, producing some excellent artwork entirely suitable for a children's book. Once the book

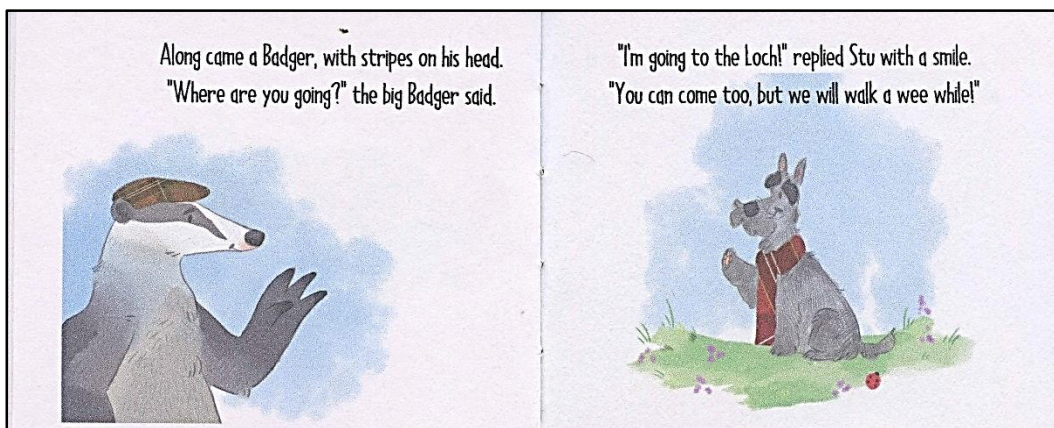

*Stu, (on the right) and his new buddy Badger, (on the left),
both in all of their finery, ready for an adventure*

was finished, edited, and re-edited, a few printed copies were made for submission to her tutors. I decided that I would produce a miniature version of the book to see if I could raise some funds for Mariam's university costs, and this resulted in the book you see in the picture.

The book received an excellent response from her tutors, and the 'icing on the cake' came when I took a copy to a local publisher and children's bookshop. The proprietor

immediately asked if she could publish it (at full size). What an achievement for a young self-taught artist, and more is to come! ”

The Adventures of Stu is hardbound and 2½" x 3". There are thirty pages each with full color illustrations and text. As with all great children's books 'Stu' also provides the reader with a bit of a challenge, 'to find the ten lady bugs that are part of the illustrations. Count them 1, 2, 3, -- --10. There is also a QR code imprinted on the 'dedication page' which leads you to a number of language activities for children. The front and rear covers are full paper illustrations which were laser printed and applied to the cover boards once the book cloth spine had been fixed with a bright red cloth tape. The endpapers are red paper as well with a lot of 'little doggy footprints, wandering across the hills'. The current edition includes 20 copies, which are available at \$20 plus postage from Stephen Byrne. 📖

*Contact information: Stephen Byrne, Castletown Wigtown Road, Sorbie Wigtownshire,
DG8 8EL Scotland
E-mail: sb@finalscore.email.*

FRONTISPIECE, Thoughts for a New Miniature Book:

Continued from page 2:

I could not print the issue in the location like the old days of the LXIVMOS, a different city for each issue, but it was fun to put the pages together and move the process along while watching to the gulls drift across the sky, smelling the waves kissing the beach, and listening to the children play in the lighthouse.

Miniature books have been written and published on an endless list of subjects: dogs, people, books, trains, recipes, events, poems, trees, the list goes on and on. One feature that has been used frequently is the practice of ‘tipping in’ a stamp, as the frontispiece for the miniature books. The book size and the stamp go well together. The proportions of each are just right for a perfect fit and there are as many stamps as there are days in the calendars of many years. There is even a set of miniature books published about ‘stamps used’ in miniature books; *Miniature Books Relating to Postage Stamps*, Levitan, Kalman L., 1983, Black Cat Press, (2 volumes).

Has anyone every published a miniature book about lighthouses? I do not know the answer to the question. There was one MBS Conclave keepsake about a lighthouse in Boston harbor. However, it seems like it would be a subject area that could spread across the realm of fact or fiction, history or a tall tale.

*‘Great lights in History’, Hatteras or Alexandria
‘Oldest light’, ‘Tallest light’, ‘Brightest light’
‘Living at the light’ or ‘Lights and the weather’*

The list is a treasure chest of subjects, who can take up the charge and bring a new miniature book to the eyes of our readers? Give it some thought it would be a fun project. 📖



USPS 2013 'Boston Light'

MINIATURE MUSIC BOOKS,

Part I: 1500-1900,

By Gail Curry:

Music inspires the mind, brings joy to the heart and frees the soul...

Music is the universal language of mankind. It has the power to bring joy, peace, and healing. At this difficult time in our nation's history, we are struggling through a pandemic, with more than 150,000 lives lost and millions of jobs in jeopardy or lost. There is violence and destructive looting in dozens of our cities across the country, along with calls to de-fund and dismantle our police. The result has been a major disruption of our lives. However, we will get through this.

Through all the uncertainty, music has been shown to enhance people's mood. A 2003 Penn State University survey, by Dr. Valerie N. Stratton, (reported on Oct. 15, 2003), showed that students who listened to music felt "more optimistic, joyful, friendly, relaxed and calm". A separate 2013 study at the University of Missouri by MU doctoral student Yuna Ferguson, (reported on May 14, 2013), showed that music was proven to have an enormous effect on mood enhancement, and the resulting "happiness relates to a higher probability of socially beneficial behavior, better physical health, higher income and greater relationship satisfaction." More importantly, music has the power to make us resilient and strong. This is not to diminish the power of prayer and other aspects of our faith. Music enhances our religious beliefs, and it is this music that is often found in miniature books.

1. The earliest music text was published in miniature in 1506 by Luca Antonio Giunta. It was entitled *Monastici cantus compendiolum*, and was dedicated to monastic choir singing. The chants are printed in black on red staves with woodcut illustrations and opening letters. One full-page woodcut is of David playing the violin. A portion of that woodcut is used as the opening initial. They were so well used by the monks for daily worship, that there are very few copies extant five centuries later. It was printed in Venice and measures 3" x 2-1/4". See Bromer & Edison pp.12,14 (includes pictures).

2. According to Doris Welsh in her book *The History of Miniature Books* (p.87), *Psalms (The Whole Book of)* is the earliest miniature book with music notation found in her bibliography. It was printed in London in 1626 by the Stationer's Company. It measures 3-5/8" x 2-3/8", with the pagination (25), 221pp., (26). The type is 8-point black letter. It contains music notation on many pages, and the music was printed from musical type. The staves and notes were cast in separate pieces of type, and a bar of music was produced

by placing the pieces of type together, thus movable type. This was later replaced with engraved music notations. See also Spielmann 425

3. According to Bondy (p.150), the best-known collection of English songs is *The Little Warbler*. The earliest dated edition that he describes is an 1803 edition published and printed in Edinburgh by Oliver & Co. (later Oliver & Boyd). My copy is entitled *The Little Warbler* Vol. 1. Scots Songs. Edinburgh: Printed by Oliver & Boyd, n.d. However, 1803 is written in faded pencil on the reverse of the title page, which has the wood vignette of the bird. 2-9/16" x 1-5/8", brown leather, 142 numbered pages. There is no music notation. Bondy pp.150, 151. *The Microbibliophile* Vol. XXX No.5, pp.6, 7

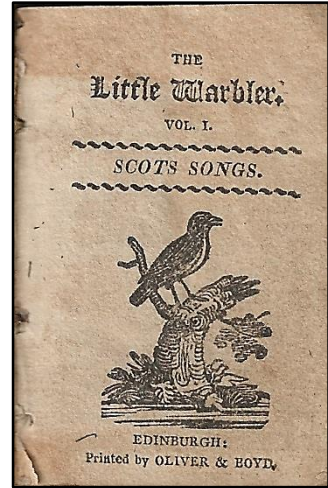

4. *The Diamond Songster*, a three-volume set, contains the first miniature song books published in America. This was published in Baltimore by Fielding Lucas, Jr. in 1812. This 1812 edition was printed by R.W. Sower & Co. and measures 2-1/2" x 1-3/4". Brown morocco, all edges gilt and gilt spine letters. Each volume is divided into two parts. The first volume is "English Songs" (sentimental and humorous), the second "Scotch Songs" (sentimental and lively), and the third "Irish Songs" (sentimental and humorous). Each of the six parts has the same pagination [3], 70pp., [2]. Lucas also published a second slightly larger set in just two volumes in 1817. This was the first American miniature book of songs, a reprint of a similar English book of English, Scotch and Irish songs. Bradbury p.57

5. Another early book with music notation is Izaak Walton's *Compleat Angler*, first published in 1653 by T. Maxty in London. Some, but not all of the books in this first edition have music notation on pp. 216 & 217, with page 217, the bass part, placed in upside down for ease of singing from such a small book. A Pickering Diamond Classic *Complete Angler* by Isaac Walton was published in 1825. According to Wilbur Macey Stone [as quoted in the Preface to Hurley Books Catalog on Miniature Angling Books, 2012], "Doubtless the most esteemed of the Diamond Pickeringings is Walton's Angler. This ... has the cuts of fishers and the music, without which we would not be satisfied with the Angler... and is an ideal volume for the pocket." The Angler's Song appears on p.186 with its accompanying music. Welsh p.88

The *Aeolian Harp* is a popular song book published by four U.S. publishers between 1818 and 1839, as follows:

6. *Aeolian Harp*. New York: Charles Starr. Stereotyped, 1818. 2-5/8" x 2-1/8", gilt leather, iv, [5], 6-124, [4]pp. The first American Edition of this title. B161

7. *Aeolian Harp*, or Songster's Cabinet. New York: R. and W.A. Bartow, 1820. 2-3/4" x 2-1/8", printed paperboards or paperboards with leather spine. [3], 2-124pp. B190

8. The *Aeolian Harp*, or songster's cabinet, being a selection of the most popular songs and recitations, patriotic, sentimental, humorous. Philadelphia: S. Hart & Son, 1829. 2-1/2" x 2", gilt leather, [3]. 4-124, [4]pp. B361

9. *The Aeolian Harp*, or Songster's Cabinet, being a selection of the most popular songs and recitations, patriotic, sentimental, humorous, etc. Philadelphia: Charles Bell, Market St., ca. 1833-1839. Gilt leather or pictorial gilt cloth. 2-5/8" x 2-1/4", [3], 4-124, [4]pp. B456

10. *Collection of Hymns for the Use of the People Called Methodists* by the Rev. John Wesley, A.M. Late Fellow of Lincoln College, Oxford, London, printed at the Conference Office, 14, City Road, by Thomas Cordeux, Agent: Sold by Thomas Blanshard, City-Road; Also, at the Methodist Preaching Houses in Town and Country, 1815. 2-3/4" x 1-5/8", full brown leather with elaborate gilt decorated spine title Wesley's Hymns, 536pp. Extremely small font.

11. *A Collection of Hymns for the Use of the Methodist Episcopal Church Principally from the Collection of The Rev. John Wesley Late Fellow of Lincoln College, Oxford*. Revised and Corrected, with the titles of appropriate Tunes, and the corresponding page of the Harmonist, prefixed to each Hymn. New York: B. Waugh & T. Mason, For the Methodist Episcopal Church at the Conference Office, Crosby-street. J. Collord, Printer, 1833. 3" x 2", elaborate gilt brown leather with spine title Methodist Hymns, 549pp., all edges gilt. Extremely small font. B453

12. The Mother's Hymn Book: Compiled from Various Authors and Private Manuscripts for the Use of Maternal Associations, and for Special Occasions of Social and Private Worship by Thomas Hastings. New York: Ezra Collier, 148 Nassau Street, 1836. 3" x 2-1/2", brown cloth with gilt imprinted title on front cover, 192pp. B544 Dedication page states:

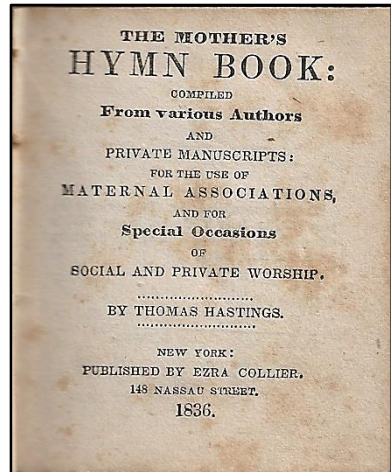

*To All Christian Mothers
And especially
To the Numerous and Interesting
Maternal Associations
Of the United States
This Little Volume
Is Most Respectfully Dedicated,
With the hope that it may
Contribute to the
Spiritual Edification of
Parents and Children
Of the present Generation.*

The Compiler.

13. Another rather elusive book is [*Schloss's*] *English Bijou Almanac for 1837*. Poetically illustrated by L.E.L. (Letitia Elizabeth Landon). This was published by Schloss in London [1836]. Measuring 13/16" x 9/16", in fraise-colored boards, lyre surrounded by flowers, this book, stamped in gilt on both covers, gilt edges, contains 4 pages of music for the "Rondo" in Balfé's Opera, 'The Maid of Artois' produced the previous May. Though petite in size, the engraved music notation is very clear. Similar slipcase, but with different gilt decoration: Lyre within frame, flanked by two flowers, topped by a crown. These Almanacs were published through 1843. The Almanac for 1838 is also of musical interest with a chapter on Mozart, but without music notation. The Almanac for 1839 contains a chapter on Mendelssohn, again without music notation. To my knowledge, the 1837

edition is the only one with music notation, thus considered rare. *Miniature Book News* Number 54, Sept., 1987; Welsh p.88, Spielmann 140

14. In a Special Issue of *The Microbibliophile* Vol. XXX No.5 of August 2011 (p.7), Stephen Byrne writes a review of *Moore's Irish Melodies, and other poems with a melologue upon national music*, by Thomas Moore. Moore published a series of poems set to well-known Irish melodies. Byrne was not able to trace a copy with the music notation. He describes a 'words only' copy published in Dublin by John Cumming. There is no date, but according to Spielman (378) it was published ca.1840. 3-5/8" x 2-1/8", gold stamped on front and rear boards with gilt spine title along with a crude design that appears to be a church, all edges gilt. The type is ca.5 point and very clear. Spielman cites his copy as in dark blue ribbed cloth, while Stephen Byrne's copy is bound in green leather. Spielmann 378.

Note: A melologue is a mixture of speech and song. The Oxford Dictionary defines it as "a recitation which is partly sung and partly spoken."

15. *Hymns for Children in Prose* (Chapbook) by Mrs. [Anna Letitia Aiken] Barbauld. New Haven: S. Babcock, ca. 1840. 2-3/4" x 1-3/4", green pictorial self-wraps, 8pp., advert on back cover for new toy books. Three black & white woodcuts to illustrate the three hymns. Another copy has been seen in tan wraps. Bradbury B647

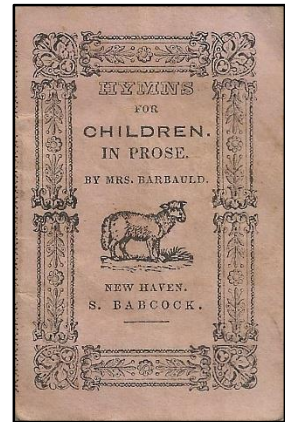

16. *Dr. Watts's Songs for Children*. (Chapbook). Worcester: H. J. Howland, No. 5 Goddards Row. 3- 1/8" x 1-3/4", yellow pictorial wraps, [3], 4-8pp.. Illustrated. Bradbury B654

17. *Y Caniedydd* (The Singer), a hymn book published in the Welsh language. Published in Llanrwst, North Wales by John Jones, ca.1840. It measures 1-3/4" x 1-3/8". No binding info known. It was intended for the use of children in Sabbath Schools. The British Library catalogue lists four other similar editions. Bondy p.133. No known music notation.

18. *Psalms and Hymns Adapted to Social, Private, and Public Worship in the Presbyterian Church in the United States of America. Approved and Authorized by The General Assembly, along with Selections from the Book of Psalms in Metre According to the Version Used in the Church of Scotland and Authorized by The General Assembly of The*

Presbyterian Church in the United States. Philadelphia: Presbyterian Board of Publications. No. 821 (first title) No. 265 (second title) Chestnut Street. (1843) n.d. 3-1/8" x 2-1/2", elaborate gilt decorated brown leather, all edges gilt. 745 numbered pp. Includes 50pp. of Indexes. B746

19. *Songs, Divine and Moral, by Isaac Watts, D.D. to which is prefixed A Memoir of the Author.* Philadelphia: Loomis and Peck, 1846. 3-1/4" x 2-5/8", green cloth with elaborate gilt spine with title Watt's Divine Songs and gilt picture on front cover, 191pp. Numerous black and white illustrations. No music notation. B791

20. *Songs Divine and Moral, For the Use of Children* by Isaac Watts D.D. Boston: G.W. Cottrell, 36 Cornhill, ca.1856-1870, ink inscription on front free endpaper dated 1862. 3" x 2/12", elaborate gilt decorated blue cloth with gilt title on front cover, 96pp. with Contents on last two pages. Numerous full page black & white illustrations. No music notation. B1089

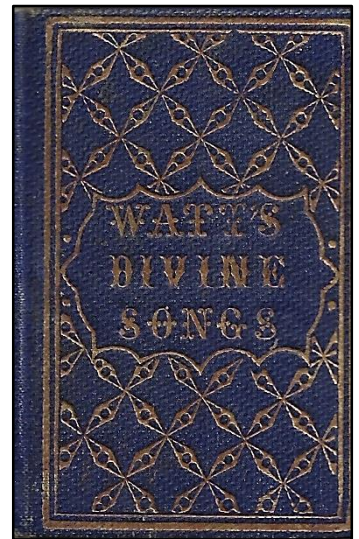
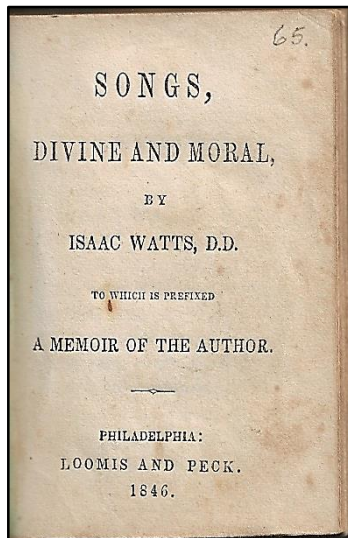

21. *The Album of Sophy Horsley*, is a one of a kind miniature album compiled by Sophy Horsley and Felix Mendelssohn, a family friend. Spanning 30 years between 1832 to 1862, the album contains musical compositions, autographs and drawings of musical interest by over 100 well known composers, artists and writers. Written in London, Dresden and elsewhere, the book measures 1-7/8" x 1-1/4" with 144pp. Composers include Brahms, Chopin, Mendelssohn, Schumann, Paganini and Liszt among the most important. This amazing little book was passed down through generations of Horsleys, and was auctioned at Sotheby's London in December 1999. This is one of the most impressive miniature books I have seen. Bromer & Edison p.30 (with pictures of some interior pages).

22. A beautiful well produced series of four songbooks was published in 1858 by Joseph Myers & Co. of Leadenhall St. in London. The titles are *The Fairy Songster*, *The Elfin Songster*, *The Peri Songster* and *The Naval Songster*. The last title is a choice collection of the most popular sea songs and ditties. These volumes are 2-1/4" x 1-7/16" and have 128pp. each. The very small type is printed in blue and bound in elaborately gilt plum, colored, orange, green and blue cloth. All four books are found in the original box. Very rare. Bondy p.151.

23. *Hymns Ancient and Modern* for use in the services of the Church. Complete edition was published as a companion volume to the *Book of Common Prayer*, and is sometimes found bound with it. They were printed by William Clowes & Sons in London, ca. 1895. 2-1/8" x 1-3/4", frequently bound in publisher's morocco with gilt cross on front cover, spine title in gilt, red edges gilt, 861pp. Sometimes found in limp brown leather. Again, no known music notation. Bondy p.131, Spielmann 208

24. A series of patriotic songs were published with music by E. T. Hazeltine in Warren, PA. These were all published ca. 1896, just before Hazeltine became Piso. They were in printed wraps, measured 3-1/16" (some 3-3/16") x 2-1/8" with 12 numbered pp. each. The titles are:

Hail Columbia by F. Hopkinson B1600

Battle-Hymn of the Republic by Julia Ward Howe B1601

America by Samuel Francis Smith B1602

Star Spangled Banner by Francis Scott Key B1603

The Stars and Stripes Forever, Patriotic Song and Chorus by George M. Vickers and Frank L. Armstrong B1604

Yankee Doodle B1605 See also Bradbury p.207, #49-54

Note: I watched the televised Inaugural Parade for President Ronald Reagan's first Inauguration in 1981. When the Mormon Tabernacle Choir floats pulled up in front of President Reagan, they sang The Battle Hymn of the Republic. It was the President's favorite, and he could not hold back his look of wonderment and eventually the tears. It reminded me of the first time my young grandson, only a couple of months old at the time, first heard Bach. The smile on his face and the movement of his very young body to the beat was another expression of wonder. Music does this.

25. A delightful finger book was published ca.1900 by David Bryce & Son in Glasgow. It was *Some Old Scotch Songs* compiled by William Moodie. Bound in red silk tartan and with all edges gilt, it has a red border around every double page of song. 3-1/4" x 1-1/8". Unpaginated. Contents list 13 songs printed with soprano line on the staves and with tune indicators and the actual words. Songs include Annie Laurie and Auld Langsyne among others. Gold & white endpapers with STUART printed on bottom left of front fixed endpaper. *Henderson News-Letter of the LXIVMOS*, No.7, May 15, 1928.

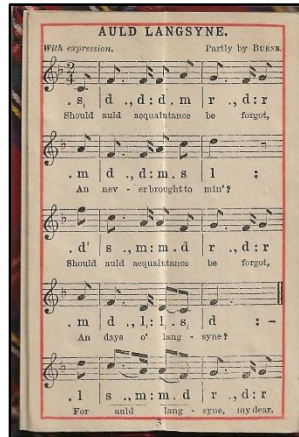

Note: At about this same time, Bryce published in Glasgow the smallest music book in the world to date, English, Scotch and Irish Songs. This was only 1" tall by 3/4" wide. Also in #7 above.

Summary: These miniature music books (most under 3 inches with a few up to 3-1/2 inches) represent the years 1506 to 1900. They are by no means a complete list for that time period. Some have music notation. Many do not. In Part II, I will discuss miniature music books of the twentieth and early twenty first centuries. As always, additions and corrections are welcomed.

References Cited:

Penn State Study <https://www.psu.edu/ur/2003/musicandstudents.html>

University of Missouri Study <https://munewsarchives.missouri.edu/news-releases/2013/0514-trying-to-be-happier-works-whenlistening-to-upbeat-music-according-to-mu-research/>

Bondy, Louis W. *MINIATURE BOOKS: Their History from the beginnings to the present day*. London: Sheppard Press (1981).

Bradbury, Robert C. *ANTIQUÉ UNITED STATES MINIATURE BOOKS 1690-1900*. No. Clarendon, Vermont: The Microbibliophile, 2001.

Bromer, Anne C. and Julian I. Edison. *MINIATURE BOOKS: 4,000 Years of Tiny Treasures*. NY: Abrams in association with The Grolier Club, New York., 2007.

Henderson, James D., Scrivener. *THE NEWSLETTERS OF THE LXIVMOS*. Complete 21 Issues. November, 1927 - November, 1929. Foreword and Index by Robert E. Massmann. Woodstock, Vermont: The Lilliputter Press, 1968

The Michrobibliophile. Vol. XXX No.5, August 2011, SPECIAL ISSUE: Ireland.
James Brogan, Editor

Miniature Book News, Number 54, Sept. 1987. St. Louis: Julian I. Edison, Editor.

Miniature Book News, Number 77, June 1993. St. Louis: Julian I. Edison, Editor.

News-Letter of the LXIVMOS, No.7, May 15, 1928, James D. Henderson, Scrivener
Spielmann, Collectd by Percy Edwin, Ph.D.

CATALOGUE OF THE *LIBRARY OF MINIATURE BOOKS* together with some
Descriptive Summaries. London: Edward Arnold, n.d.

The History of Miniature Books, Welsh, Doris V., Albany, NY: Fort Orange Press, Inc.,
1987

A Bibliography of Miniature Books (1470 - 1965), Welsh, Doris V., edited for publication
with a Preface by Msgr. Francis J. Weber. Cobleskill, NY: Kathryn I. Rickard, 1989 (1965)

Contact information: Gail Curry, 1041 Bomar Court, Mars, PA 16046
E-mail: curry.gail@att.net

TERMS AND DEFINITIONS,

Printers Terms,

Quads and Type:

There are always words used to define or identify certain 'things' that we may know about or have seen many times but are not exactly sure how to properly define that 'thing'.

A quad is a 'blank piece of type', which is cast just a bit 'shorter, not as high' as the regular type in height. The quad is used for inter-word spacing and its job is to hold the line together but not add any 'text or impression to the printed page. Sometimes the device is referred to as a 'space'.

During much of the letterpress process, movable type was composed by hand for each page. Cast metal sorts or 'letters' were composed into words, with quads (for spaces), then lines, then paragraphs, then pages of text and then tightly assembled to make up a form. All the letter faces would be exactly the same 'height to paper', creating an even surface of type. The form was placed in a press, inked, and an impression made on the paper.

This diagram illustrates a cast metal 'sort' for the letter 'H', a quad would be similar but with no face (a).

a face, **b** body or shank, **c** point size

1 shoulder, **2** nick, **3** groove, **4** foot.

Set width, like body size, is measured in points.

A short lesson in terms.

Who knows what the term 'dingbat' means? 📖

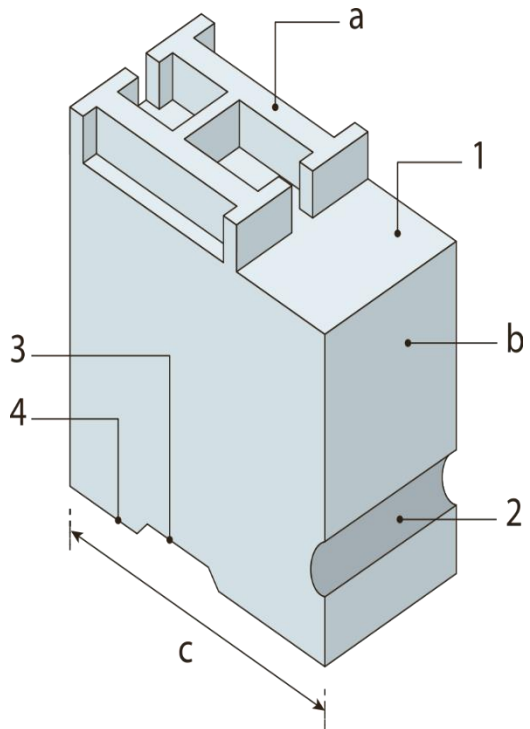

CLASSIFIED WISH LISTS,

Buy, Sell, or Trade:

As a feature for subscribers, *The Microbibliophile* offers a classified listing service with each issue. Each message should be no more than 250 characters. Send your information to the Editor for inclusion in the next issue.



Darleen Cordova is looking for (Hazeltime) Piso Pocket Book Almanac for 1918 to complete her set of the 12-month almanacs.

Contact information: E-mail: c.cordova@sbcglobal.net or 714-808-9648

Neale Albert is looking for two miniature books by Asao Hoshino – *Kwaidan* and *Ichiaku No Suna*, and for the special editions of the Asao Hoshino books. "I am thinking of doing a Hoshino bibliography". Contact information: E-mail: nma8156@yahoo.com

Karen Nyman is looking for two volumes she lacks from *The Cabinet of Lilliput*, by John Harris. Here are the missing titles: *Jacob the Fisherman*; etc., and *Julia and the Dog*, etc. Contact information: E-mail: karennnyman2@gmail.com or call 760-944-3019

Pat Pistner is looking for 28 Raheb books (Mudlark Miniatures and Littlest Library) published in 1976 and 1977, and only 19 published.

Contact information: E-mail: Pistner@me.com

Arno Gschwendtner is looking for a French miniature book (MB) ca. 1830: Bernardin: Paul et Virginie (printed from Didot) - he wants to write an article about this book – please send pictures (and an offer) of your edition. He is also looking for 'Special Editions' of the Catharijne Press as well as Editions du Capricorne from Anick Butre (France).

Contact information: E-mail: arno.gschwendtner@gmx.ch or +41/78/8542422

Caroline Brandt is looking for Colgate Calendars for 1884, 1887, 1889, 1891, and 1893 Also *Red, White, and Blue* by Frank L. Armstrong. Lastly, two miniatures by W. Washburn; *Adventures of A Bottle of Pain-Killer* (1879) and *The Cat; His Immortality* (1880).

Contact information: 1500 Westbrook CT # 1109, Richmond, VA 23227

Todd Sommerfeld is looking for two Pairault et Cie titles, *Ali Baba*, and *La Fontaine* to complete his *La Gracieuse*. Contact information: E-mail: contratodd@gmail.com or 216-965-7490.

Jim Brogan is looking for a tome, *The 70th Academy Awards*, by Gloria Stuart.

Contact information: E-mail: jbrogan1@verizon.net

For Sale: Now offering some interesting Dawson Book Shop publications from the past several years. Additionally, there is a nice selection of Msgr. Francis Weber's 100+ miniatures available with many copies signed by Weber, most letterpress printed, as low as \$10 per volume, plus postage, contact the editor for an Excel list with titles and prices. Email: hello@themicrobibliophile.com

Free for the printing! Please review your ad content and let me know about any updates that may be needed to help your searches. 